



Friction Stir Welding European Qualifications

CU02 – Joint Preparation and Definition

FSW Specialist and Engineer



Co-funded by the
Erasmus+ Programme
of the European Union

2. Joint Definition

- 2.1 Considerations for the Joint Design
- 2.2 Cleaning Methods
- 2.3 Tools
- 2.4 Clamping
- 2.5 Backing Plates
- 2.6 Parent Materials
- 2.7 Equipment for FSW
- 2.8 FSW-Tech Parameters
- 2.9 Programs
- 2.10 References

2.1 – Considerations for the Joint Design

2.1.1 Types of Joints

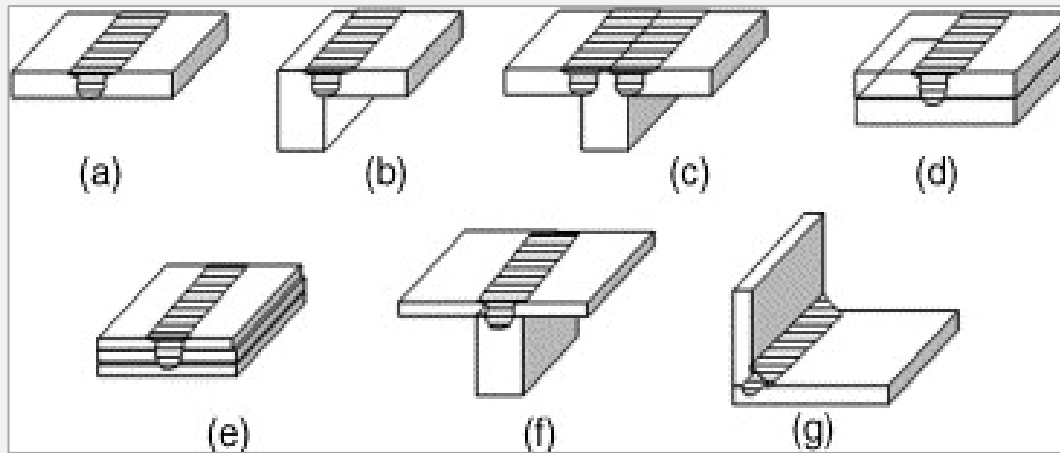

- a. Square butt
- b. Edge butt
- c. **T butt joint**
- d. **Lap joint**
- e. Multiple lap joint
- f. T lap joint
- g. **Fillet joint**

2.1 – Considerations for the Joint Design

2.1.2 Design Considerations

Joint design should take into account:

- ✓ Area for the welding tool shoulder path – function of material thickness and alloy
- ✓ Containment of softened weld metal along the full length of the joint
- ✓ **Force** to prevent motion of the workpieces
- ✓ **Heat sinks** to dissipate the heat of welding

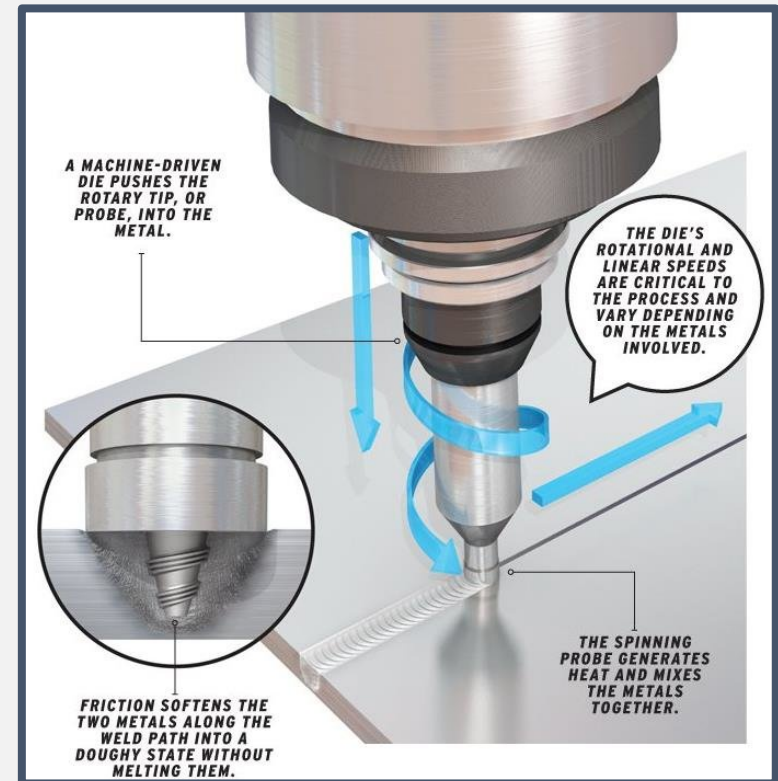
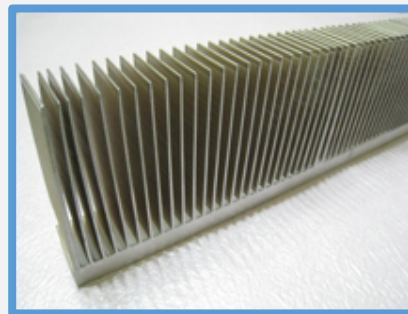
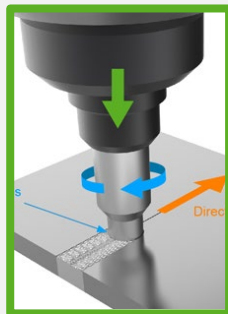

2.1 – Considerations for the Joint Design

2.1.2 Design Considerations

- Inappropriate clamping may lead to **“drop-out”** this is the result of inadequate vertical force in a butt weld, preventing the workpiece from lifting from the anvil.
- This is properly prevented by ensuring a good fixture design, rather than **trying to correct during the welding process**.

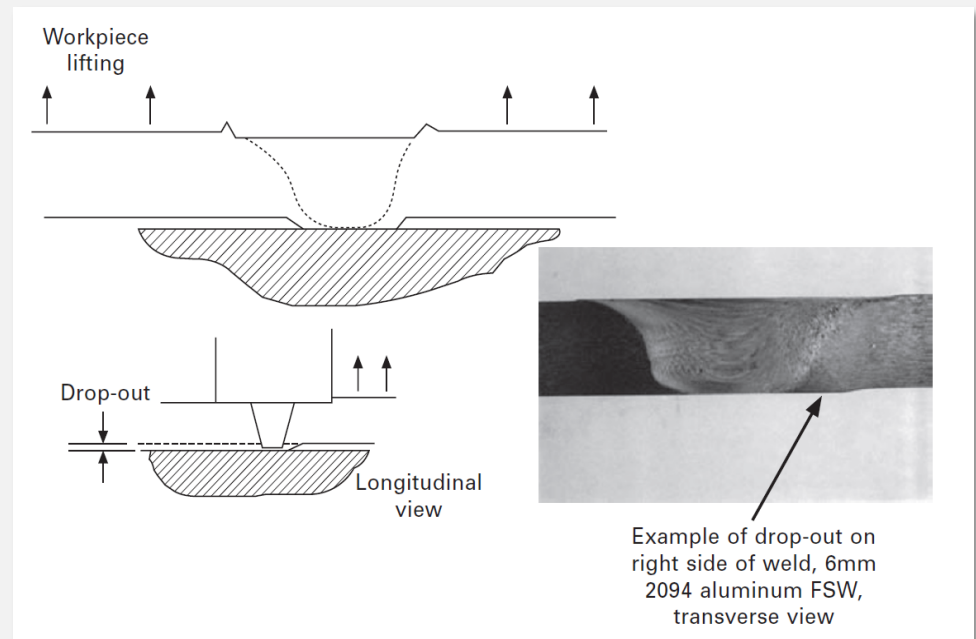

Drop-out in a butt weld produced by inadequate vertical holding force on the workpiece

2.2 – Cleaning Methods

2.2.1 Importance of Cleaning

- Necessary step for a successful joint
- Remove dust, grease or moisture
- Negative fallouts of improper surface cleaning:
 - Poor fatigue loading performance
 - Localized low ductility
 - Volumetric defects

Most common cleaning method:

- ✓ Solvent and wiping it down with a paper towel

Other cleaning methods
(*not commonly used*):

- ✓ Grinding
- ✓ Wire Brushing
- ✓ Paint Removers
- ✓ Pickling

2.2 – Cleaning Methods

Advantages

Avoidance of:

- Poor fatigue loading performance
- Localized low ductility and volumetric defects produced during post-weld heating

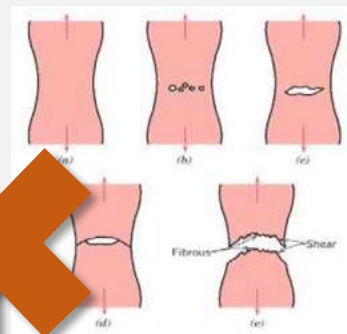

Disadvantages

Increase the price of the process

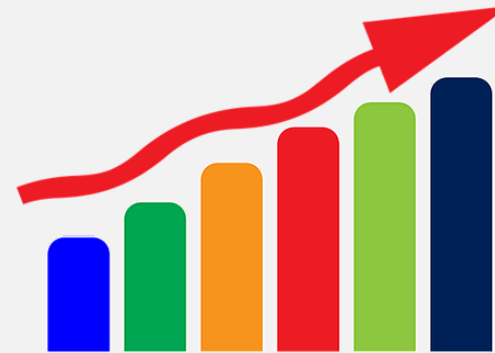

2.3 – Tools

FSW Tools:

- ✓ Non-consumable
- ✓ Key component of the FSW process

Tool **material** and **geometry** depends on:

- ✓ Material to be welded
- ✓ Dimensions
- ✓ Joint configuration
- ✓ Other required specifications

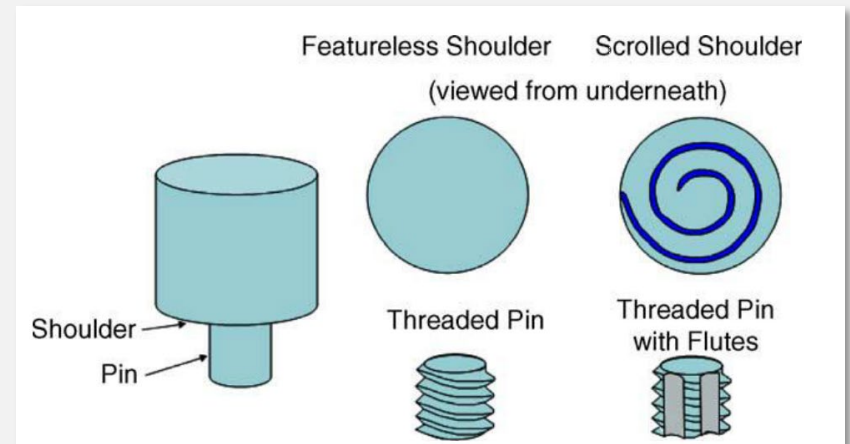

Basic tool shoulder and pin features

2.3 – Tools

2.3.1 Types of tools and its characteristics

Six basic characteristics to select a tool:

- ✓ Strength at ambient and process temperature
- ✓ Fatigue life at process temperature
- ✓ Fracture toughness
- ✓ Wear characteristics
- ✓ Long term thermal stability
- ✓ Chemical stability (*nil or limited reaction with the workpiece*)

How to select a tool?



2.3 – Tools

2.3.1 Types of tools and its characteristics

Some Examples

- To weld aluminium alloys (most common application of FSW) → tool steel materials
 - Aluminium alloys (6 to 12 mm thickness) → it's usually employed H13 tool steel
 - For higher thicknesses or if an increase of productivity is needed:
 - the **pin tool** can be made of **high strength materials** at the welding temperature
 - but the **shoulder** of the tool can still be made from **H13**
- For some specific cases – development of more elaborate tool designs, delivering better performances
- To weld other materials, such as titanium, steel or copper may require tools made from tungsten-based materials, polycrystalline cubic boron nitride or other high performance materials that endure high temperatures

2.3 – Tools

2.3.2 Positioning

Offset position

- The offset position corresponds to the lateral offset from the tool axis to the faying surface

Z position

- Tool movement across the workpiece is predetermined along three-dimensions (x, y, z).

Plunge depth

- Distance the heel extends into the weld metal is referenced as heel plunge depth
- Programmed and critical parameter for position-controlled runs

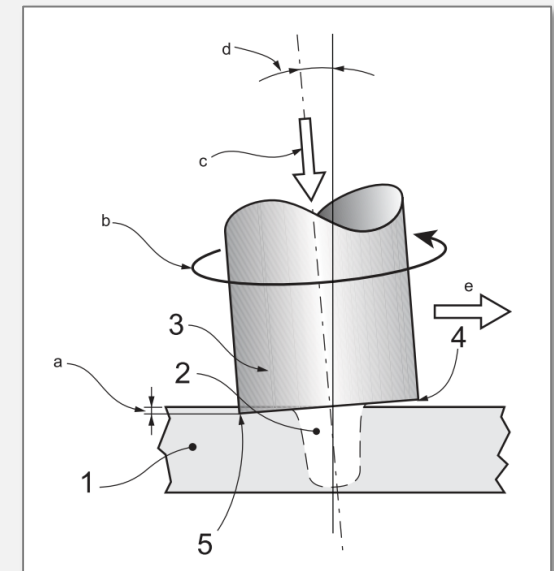

Side view of butt joint

1. Workpiece
2. Probe
3. Tool
4. Shoulder (leading edge)
5. Heel (shoulder trailing edge)

- a) Heel plunge depth
- b) Direction of tool rotation
- c) Axial force
- d) Tilt angle
- e) Direction of welding

2.4 – Clamping

2.4.1 – *Clamping methods and its characteristics*

Mechanical actuation clamps

- Simple and economic way to clamp sheets or plates
- High clamping forces
- Clamping claws mounted close to the weld seam due to different thermal conductivities
- High set-up times (to clamp the work pieces)

Pneumatic and Hydraulic clamps

- For series production in order to reduce set-up times
- These fixtures are expensive and only reasonable in batch production situations

Vacuum clamping

- Very flexible systems easy to use
- Allow for clamping of different part sizes
- Low set-up times
- Clamping forces are not always sufficient for thick plates

2.4 – Clamping

2.4.2 – *Clamping importance*

Proper clamping is an important aspect since it's always present during the welding process.

Clamping mechanisms:

- ✓ Should allow the FSW pin tool to access to the weld path
- ✓ Should prevent the part from sliding lengthwise, bending or separating due to the torque forces
- ✓ Influences weld quality and production cycle

2.4 – Clamping

2.4.3 – Clamping Arrangements

- **Locators** – resist all primary forces generated in the operation
- **Clamps** – need to hold the workpiece against the locators and resist any secondary forces generated in the operation

Clamps positioning/location:

- At the most rigid points of the workpiece – preventing it from damage
- Should ensure an equal distribution of forces throughout the whole process
- Should be selected to ensure it doesn't interfere with the welding path of operation

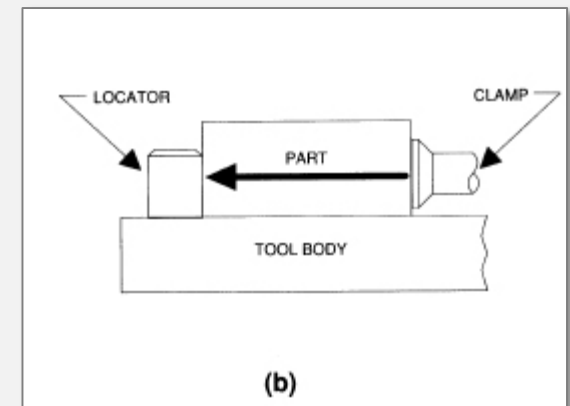
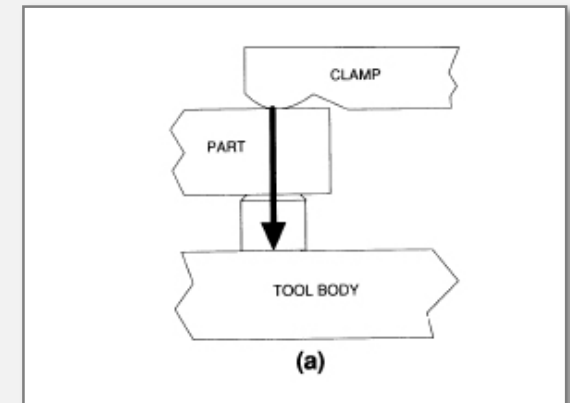

2.4 – Clamping

2.4.4 – Influence of the clamping in the welding process

Influencing factors on distortion:

- ✓ Clamp location
- ✓ Clamping time
- ✓ Clamping release time
- ✓ Pre-heating of the clamps

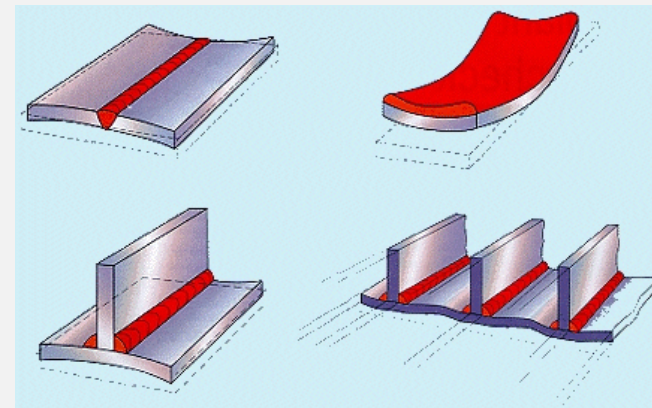

Pre-heating of the clamps → more homogeneous deformation → reduced buckling amplitude

Longer release times → reduced angular distortion

Longer clamping times → reduced bending amplitude

The closer the clamps are to the weld → smaller the final distortion

2.4 – Clamping

2.4.5 – *Jigs and fixtures*

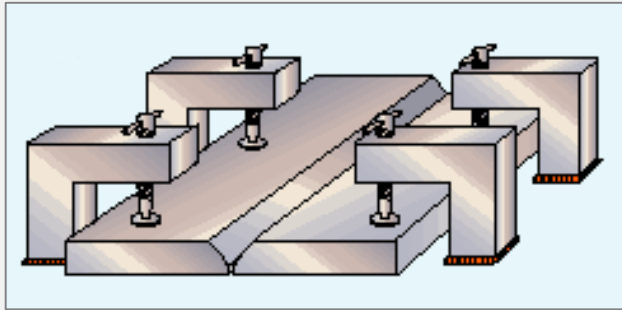

Welding jig (source: TWI)



Vacuum clamping



Frame railing



Railing welding

2.5 – Backing Plates

- ✓ Resist the normal forces employed in FSW
- ✓ Providing a stiff object to clamp the plates or sheets to be welded
- ✓ The backing plate materials influence the power consumption and the weld quality

Material	Thermal conductivity [W/mK]
Mild steel	40-60
Stainless steel	15-25
X33CrS16 (1.2085)	17
RAMAX	24
Bras	110-150
Copper	180-400
Aluminium alloys	110-235

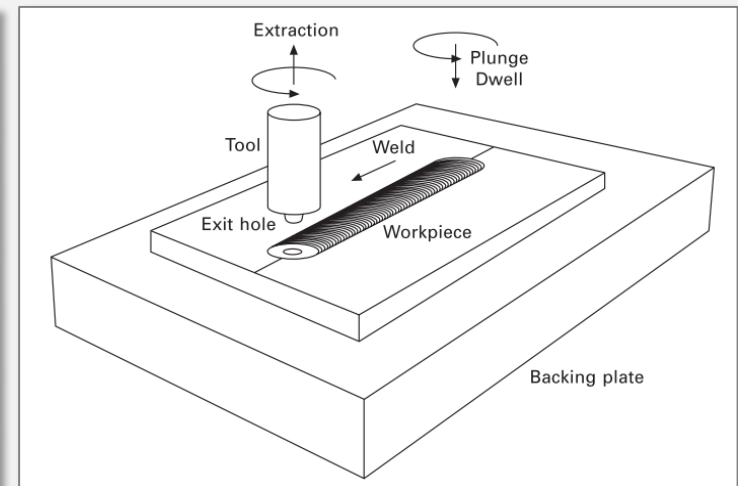

2.6 – Parent Materials

2.6.1 Adequate Materials for FSW

- High temperature alloys (e.g. titanium, steels, nickel)
- Low temperature alloys (e.g. aluminium, magnesium, copper)
- Dissimilar materials (e.g. aluminium to steel, aluminium to magnesium)
- Thermoplastics

2.6 – Parent Materials

2.6.2 Weldability of materials for FSW

- ✓ FSW improves the weldability of certain materials
- ✓ The main limitation to the weldability of high melting point metals is the availability of suitable welding tool materials that can endure these conditions of operation
- ✓ The heat generated by friction, plastic work or auxiliary heating must be sufficient to overcome the loss of heat from the welding zone through conduction on the workpiece
- ✓ Certain aluminium alloys are difficult or impossible to weld by traditional arc welding processes due to problems with the formation of brittle phases and cracking, so friction stir welding is a viable alternative
- ✓ FSW of steel has shown that the lower welding temperature can lead to very low distortion and unique joint properties
- ✓ When applying FSW to titanium it's necessary a low heat input of the tool design either by minimizing the shoulder diameter or by eliminating shoulder rotation altogether, due to its low thermal conductivity
- ✓ Copper has been applying FSW on the construction of canisters for storing nuclear waste for several years. Although it was expected that the high thermal conductivity would be a problem it was corrected through high spindle speed, which helped in delivering sufficient heat intensity for high quality welds.
- ✓ The use of FSW also enables the joining of dissimilar alloys, which can appeal to certain applications

2.7 – Equipment for FSW

2.7.1 – *Types of Equipment and Characteristics*

- FSW equipment needs to be designed in order to **ensure**:
 - Appropriate fit-up
 - Proper hold-down clamping (including enough stiffness to prevent the part from moving)
 - Dissipation of the heat generated by the process
- The critical parameters controlled by the FSW equipment are:
 - Pin tool position
 - Orientation
 - Loads
 - Rotation and travel speeds
- FSW machines are usually designed for a specific application, although there are some **general configuration machines** that can deal with different situations.

2.7 – Equipment for FSW

2.7.1 – Types of Equipment and Characteristics

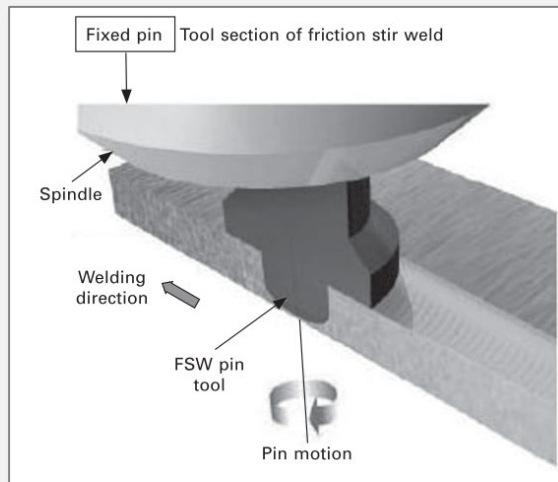

Fixed-pin

- ✓ One-piece tool, shoulder and pin
- ✓ Joint motion of the welding head spindle
- ✓ Most traditional form of FSW

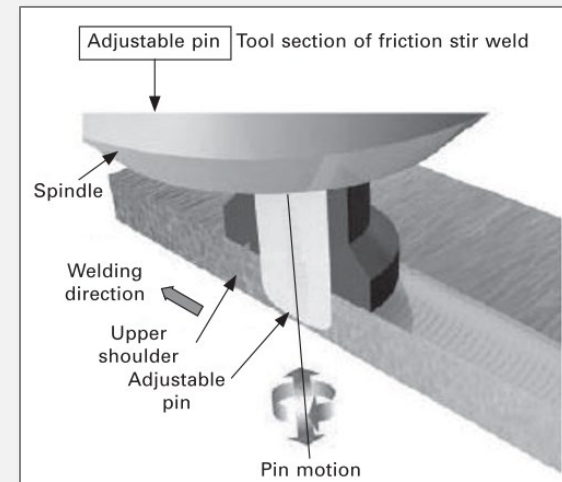

Adjustable-pin

- ✓ Uncoupling between the pin and the shoulder
- ✓ Useful to weld parts with varying thickness
- ✓ Used to close-out the pin hole

2.7 – Equipment for FSW

2.7.1 – *Types of Equipment and Characteristics*

Adjustable-pin closing out pin hole

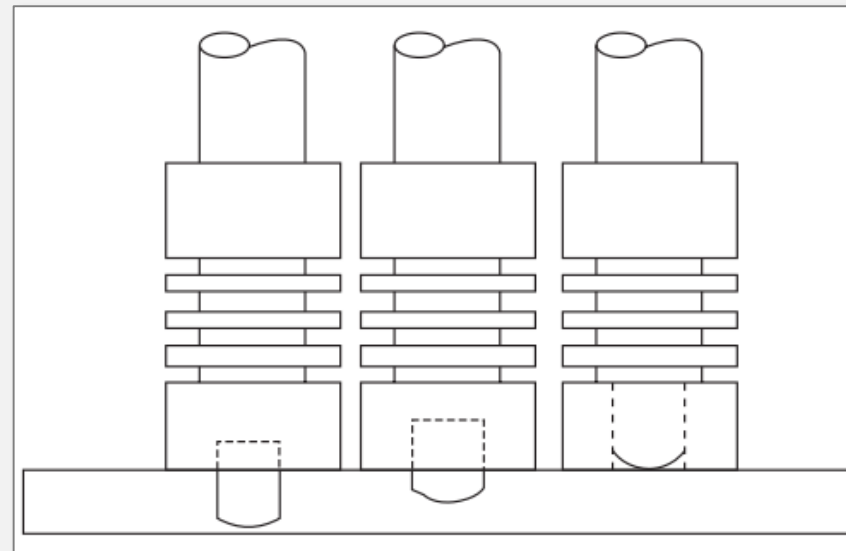

- Implies a more sophisticated machine design and control scheme
- Can move the pin and should independently

2.7 – Equipment for FSW

2.7.2 – *Productivity and efficiency of the equipment*

- Increasing the welding speed to improve productivity isn't the ideal solution
- Fixed automation and robotic solutions can be used, and its choice comes down to technical and economic factors
 - ✓ Fixed automation – machine built for a single purpose and to the exact requirements of a specific application
 - ✓ Robotic Solutions – higher flexibility
- Process productivity and efficiency are also influenced by tool design

2.8 – FSW Parameters

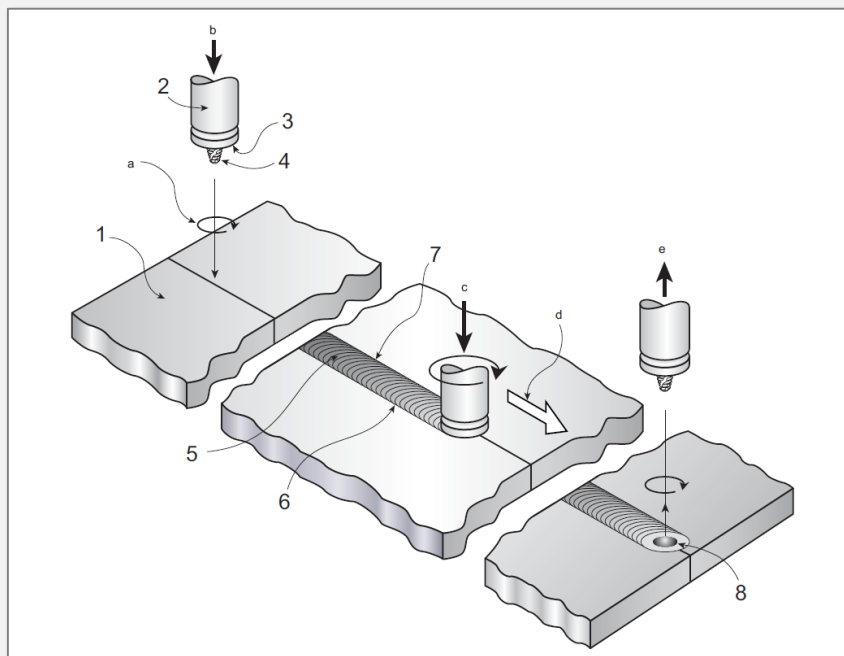

- a) Direction of tool rotation
- b) Downward motion of tool
- c) Axial force
- d) Direction of welding
- e) Upward motion of tool

Main FSW process variables

Tool design variables	Machine variables	Other variables
Shoulder and pin materials	Welding speed	Anvil material
Shoulder diameter	Spindle speed	Anvil size
Pin diameter	Plunge force or depth	Workpiece size
Pin length	Tool tilt angle	Workpiece properties
Thread pitch		
Feature geometry		

- 1) Workpiece
- 2) Tool
- 3) Shoulder
- 4) Probe
- 5) Weld face
- 6) Retreating side of weld
- 7) Advancing side of weld
- 8) Exit hole

2.8 – FSW Parameters

- ✓ Rotation speed [rpm]
- ✓ Heel plunge depth [mm]
- ✓ Axial Force [kN]
- ✓ Tilt Angle [°]
- ✓ Side tilt angle [°]
- ✓ Dwell time [s]
- ✓ Welding speed [mm/min]
- ✓ Preheating temperature [°C]
- ✓ Post-weld treatments
- ✓ Heating and cooling rates



2.9 – Programs



2.10 – References

1. S. Ebnesajjad and H. A. Landrock, "Joint Design," *Adhes. Technol. Handb.*, pp. 183–205, 2014.
2. R. S. Mishra and Z. Y. Ma, "Friction stir welding and processing," *Mater. Sci. Eng. R Reports*, vol. 50, no. 1–2, pp. 1–78, 2005.
3. D. Lohwasser and Z. Chen, *Friction Stir Welding: From Basics to Applications*. 2010.
4. R. Miller, "GUIDELINES FOR FRICTION STIR WELDING," Detroit, 2011.
5. R. S. Mishra and M. W. Mahoney, "Friction Stir Welding and Processing," *ASM Int.*, p. 368, 2007.
6. I. O. for S. (ISO), *Final Draft ISO/FDIS 25239-5*, 1st ed. ISO, 2011.
7. ESAB, "Handbook - Joint Design & Prep." [Online]. Available: https://www.esabna.com/euweb/sa_handbook/585sa2_26.htm. [Accessed: 18-Jul-2018].
8. [N. Mendes, P. Neto, A. Loureiro, and A. P. Moreira, "Machines and control systems for friction stir welding: A review," *Mater. Des.*, vol. 90, pp. 256–265, 2016.
9. G. K. Padhy, C. S. Wu, and S. Gao, "Friction stir based welding and processing technologies - processes, parameters, microstructures and applications: A review," *J. Mater. Sci. Technol.*, vol. 34, pp. 1–38, 2017.
10. P. S. D. N. K. Mishra, S. R., *Friction stir welding and processing*. 2014.
11. F. C. Liu, Y. Hovanski, M. P. Miles, C. D. Sorensen, and T. W. Nelson, "A review of friction stir welding of steels: Tool, material flow, microstructure, and properties," *J. Mater. Sci. Technol.*, vol. 34, no. 1, pp. 39–57, 2017.
12. I. O. for S. (ISO), *Final Draft ISO/FDIS 25239-1*, 1st ed. ISO, 2011.
13. A. Fehrenbacher, N. A. Duffie, N. J. Ferrier, F. E. Pfefferkorn, and M. R. Zinn, "Toward Automation of Friction Stir Welding Through Temperature Measurement and Closed-Loop Control," *J. Manuf. Sci. Eng.*, vol. 133, no. 5, p. 051008, 2011.
14. Future Weld, *Mechanized Welding - Mechanized, Orbital and Robot Welding*. 2014.
15. D. Lohwasser and Z. Chen, *Friction stir welding : from basics to applications*. Woodhead Publishing, 2009.

2.10 – References

16. T. Schenk, I. M. Richardson, M. Kraska, and S. Ohnimus, "A study on the influence of clamping on welding distortion," *Comput. Mater. Sci.*, vol. 45, no. 4, pp. 999–1005, 2009.
17. W. J. Choi, J. D. Morrow, F. E. Pfefferkorn, and M. R. Zinn, "The Effects of Welding Parameters and Backing Plate Diffusivity on Energy Consumption in Friction Stir Welding," *Procedia Manuf.*, vol. 10, pp. 382–391, 2017.
18. "3.1 Material Certificates | Classic Filters." [Online]. Available: <https://www.classicfilters.com/blog/materialcertificates/>. [Accessed: 03-Jan-2019].
19. "How to view the material certificate? – Part 1 – AMARINE." [Online]. Available: <https://amarineblog.wordpress.com/2017/09/22/how-to-view-the-material-certificate/>. [Accessed: 03-Jan-2019].
20. W. M. Syafiq, M. Afendi, R. Daud, M. N. Mazlee, and N. A. Jaafar, Variation of tool offsets and its influence on mechanical properties of dissimilar friction stir welding of aluminum alloy 6061 and S235JR mild steel by conventional belting milling machine. 2017.
21. "What Is a Welding Jig? - Tulsa Welding School." [Online]. Available: <https://www.weldingschool.com/blog/welding/what-is-a-welding-jig/>. [Accessed: 19-Jul-2018].
22. "UNIT 4 JIGS AND FIXTURES Structure 4.1 Introduction."
23. "Welding Fixtures and How They Work | Forster America." [Online]. Available: <https://www.forsteramerica.com/welding-fixtures-and-how-they-work/>. [Accessed: 19-Jul-2018].
24. D. Lohwasser and Z. Chen, Friction stir welding Related titles : 2010.
25. [26] HSE Gov.UK, "Welding fume - Reducing the risk." [Online]. Available: <http://www.hse.gov.uk/welding/fume-welding.htm>. [Accessed: 07-Aug-2018].
26. ESAB AB Welding Automation and ESAB, "Friction Stir Welding - Technical Handbook." [Online]. Available: https://www.esabna.com/euweb/sa_handbook/585sa2_26.htm. [Accessed: 18-Jul-2018].
27. D. Veljić et al., "Advantages of friction stir welding over arc welding with respect to health and environmental protection and work safety," *Struct. Integr. Life*, vol. 15, no. 2, pp. 111–116, 2015
28. S. B.; D. R. D.Muruganandam, "HEALTH HAZARDS DUE TO VARIOUS WELDING TECHNIQUES AND ITS REMEDY BY FRICTION STIR WELDING (FSW)," *Int. J. Res. Aeronaut. Mech. Eng.*, vol. 2, no. 3, pp. 96–101, 2014.



Co-funded by the
Erasmus+ Programme
of the European Union



Friction Stir Welding European Qualifications

Thank you